

CIRCLE OF CHEER				32 R
	CHAIN 2 steps/hand	D ① ⑤	T_R ① ⑤	ALL

Jo Hamilton, 1995, Let's All Dance, Too

Any/Any Round the Room.

CUTTY SARK					8x32 J
	2 1 RA LA	T_R T_L T_R X_L	2 1 3 ↓	2 1 3 T_R	

Scottish Borders Dance Festival, 1992, RSCDS Book 40.2

3C/4C longwise set.

GRANT'S REEL					8x32 S	
	S T_B	S T_B	↔	S ↻	D	2 1 RL

Rutherford, 1760, RSCDS Book 14.2

2C/4C longwise set.

GOOD HEARTED GLASGOW					8x32 J
T_R ↻	T_L1₄	RA RA	LA LA	↔	2 1 3 6

Peter Knapman, 1988, Collins Pocket Reference

3C/4C longwise set.

STAIRCASE IN STYRIA				5x40 R			
	RA _{1/4}		LA		RA		LA _{1/4}
	X_R ↻		X_R ↻		X_R ↻		X_R ↻

Margaret Gray, CD booklet of The Sunday Class Book 2

5C/5C longwise set.

THE SILVER GREY					3x32 S
1 2 3 S X_R	1x 2x 3x S X_R	6			

Roy Goldring, Graded & Social Dances 2

3C/3C longwise set.

GRANVILLE MARKET					8x32 J	
1 2 RA	1 2 LA	X_R ↻		T_R ↻	T_R ↻	2 1 3 6

Elinor M Vandegrift, RSCDS Graded Book 2.18

3C/4C longwise set.

SHIFTIN' BOBBINS					8x32 R
	S		LA	RA	LA
	X_R ↻		X_R ↻		X_R ↻

Roy Clowes, Ormskirk Book 6, RSCDS Thirty Popular Dances Vol 2

3C/4C longwise set.

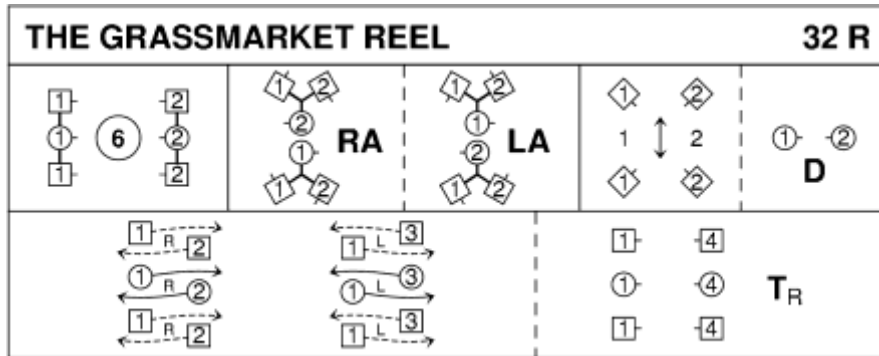

Tim Wilson, RSCDS 5/2009

2T/Any Round the Floor.

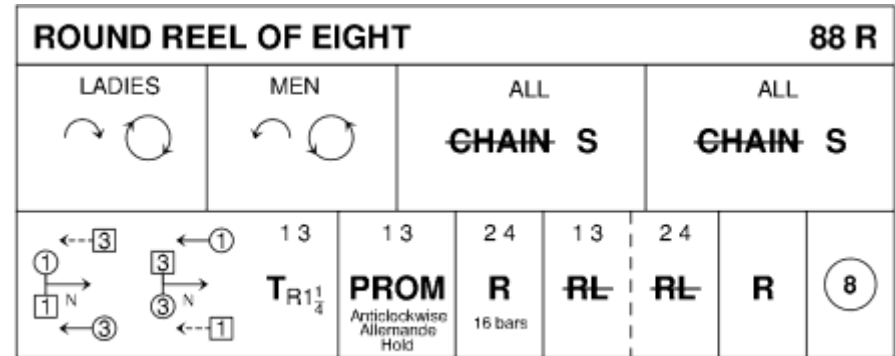

RSCDS Book 27.7

4C/4C square set.

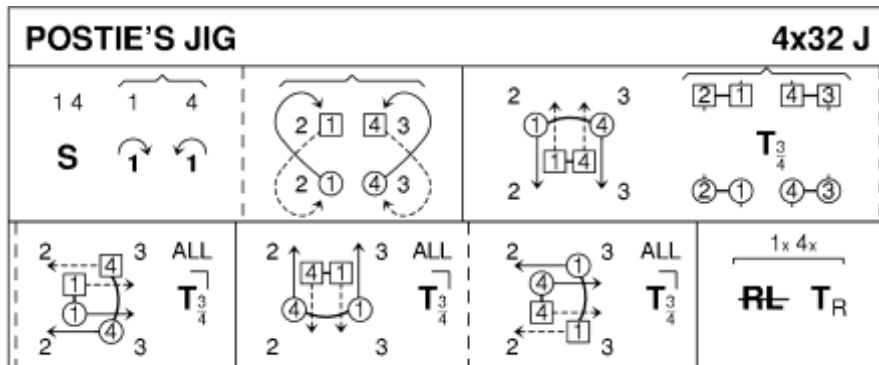

Roy Clowes, Ormskirk 5, RSCDS Thirty Popular Danos Vol 2

4C/4C longwise set.

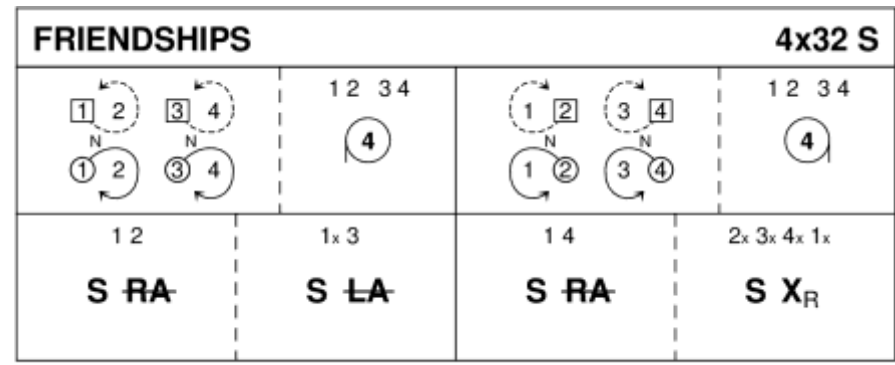

Jennie Miller, RSCDS Graded Book 3.3

4C/4C longwise set.

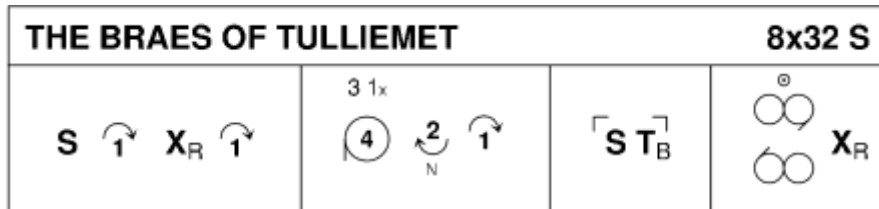

RSCDS Book 7.12

3C/4C longwise set.

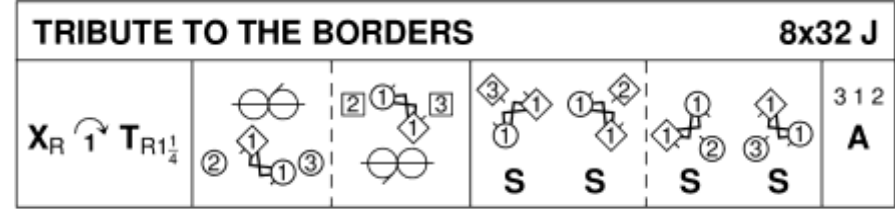

Roy Goldring, 1979, RSCDS Leaflet 11

3C/4C longwise set.

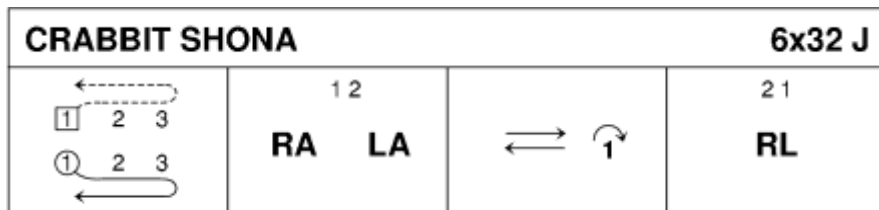

Rebecca Sager, Atlanta, <http://www.strathspey.org/lists/strathspey%40strathspey.org/mv12277/>

2C/3C longwise set

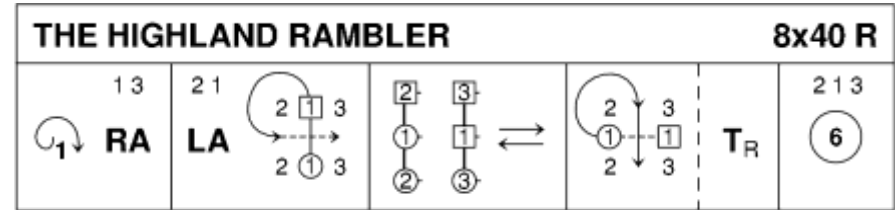

Roy Goldring, 1985, Leeds Silver Jubilee, RSCDS Thirty Popular Danos Vol 2

3C/4C longwise set.